



Dikey Tip Soğutucular
Multideck Cabinets Semi Height

PENGUEN LOW

TEKNİK ÖZELLİKLER

- Dıştan Motorlu,
- 40 kg/m³ poliüretan enjeksiyon gövdeli,
- Dijital göstergeli,
- Termostatlı ve otomatik defrostlu,
- Paslanmaz çelik teşhir tavali,
- İthal gece perdeli,
- PVC ön tampon koruyuculu,
- 2 sıra raflı,
- Bütün raflarda eşit hava dağılımı,
- Ral seçenekleri,
- Ada uygulaması
- Raf Altı aydınlatma(opsiyonel)

STANDARD FEATURES

- Remote unit
- Air ventilated cooling system
- 40kg/m³ polyurethane injection body
- Stainless steel display
- Programmable defrosting with digital thermostat
- Manual night blind for energy saving
- PVC bumper for protection
- Equal airflow between the shelves
- Adjustable 2 shelf
- RAL color choices
- Sliding Door Choices

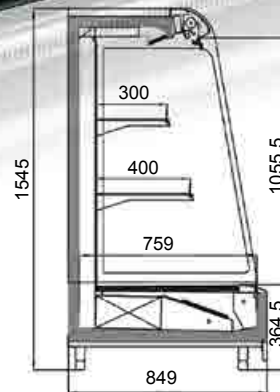

Penguen Low 90

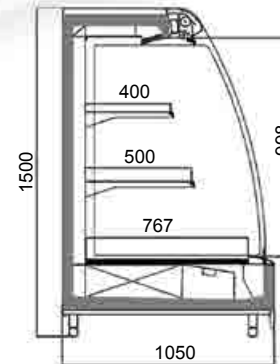

Penguen Low 105

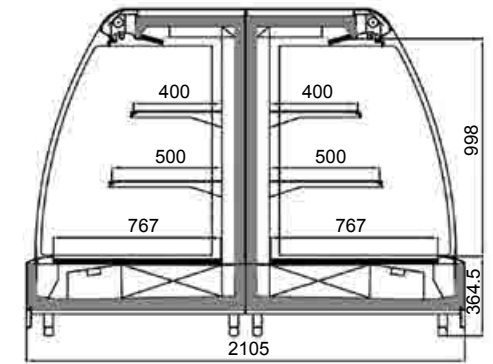

Penguen Low 105 / Back to Back